

Before performing any service always follow applicable safety precautions. Consult company safety manual or supervisor for questions concerning safety.

118MAX and 122MAX Improved Rear Cushion Installation / Retrofit

Affected Products: 118MAX and 122MAX Air Hammers
Affected Date Range: Before Serial Number BA15B0401
Related Issue #: ?

Issue Description:

The cylinder of the 118MAX and 122MAX air hammers can rotate during use. This does not affect performance or durability, but the user can find it disconcerting. The user may try to tighten the cylinder or front cap to prevent rotation of the cylinder. When the cylinder or front cap is over-tightened, the rear cushion can be damaged and/or broken.

Actions Required:

A modified "Rear Cushion" and a new part, the "Rear Cushion Seat", can be installed with the "Rear Cushion Seat Fixture" to eliminate cylinder rotation. These parts can be purchased together in the "Rear Cushion Kit", along with the "O-Ring" that sits around the Rear Cushion.

A service center only needs to purchase the full Rear Cushion Kit once. The Rear Cushion Seat Fixture can be reused on future retrofits; in this case, the service center would need to purchase the Rear Cushion, Rear Cushion Seat, and O-Ring individually.

Rear Cushion Kit Part Information:

Tool Model	Rear Cushion Kit	Rear Cushion	Rear Cushion Seat	Rear Cushion Seat Fixture	O-Ring
118MAX, 122MAX	122MAX-K304	122MAX-304	122MAX-305	122MAX-525	122MAX-282

Disclaimer:

THE MATERIALS IN THIS SITE AND ANY LINKED THIRD-PARTY SITES ARE PROVIDED "AS IS" AND WITHOUT WARRANTIES OF ANY KIND EITHER EXPRESS OR IMPLIED. Ingersoll Rand does not warrant the accuracy or completeness of the materials or the reliability of any advice, opinion, statement or other information displayed or distributed through the site nor make any representations regarding the use or the results of the use of the materials in this site or in any linked third-party sites. TO THE FULLEST EXTENT PERMITTED BY LAW, Ingersoll Rand DISCLAIMS ALL WARRANTIES, EXPRESS OR IMPLIED, INCLUDING, BUT NOT LIMITED TO, IMPLIED WARRANTIES OF MERCHANTABILITY, NON-INFRINGEMENT, AND FITNESS FOR A PARTICULAR PURPOSE WITH RESPECT TO THIS SITE OR ANY LINKED THIRD PARTY SITE. SOME JURISDICTIONS DO NOT ALLOW FOR THE EXCLUSION OF IMPLIED WARRANTIES, SO THE ABOVE EXCLUSIONS MAY NOT APPLY TO YOU. You (and not Ingersoll Rand) assume the entire cost of all necessary maintenance, repair or correction resulting from your use. Ingersoll Rand reserves the right, in its sole discretion, to correct any errors or omissions in any portion of the site. Ingersoll Rand may make any other changes to the site, the materials and the products, programs or services described in the site at any time without notice. Before performing any service always follow applicable safety precautions. Consult company safety manual or supervisor for questions concerning safety. In no event shall Ingersoll Rand be responsible for any consequential, incidental, indirect, punitive or special damages related to this site nor the information contained in this bulletin.

Assembly Fixture Information:

The Rear Cushion Kit can be installed using the Rear Cushion Seat Fixture. To use the Rear Cushion Seat Fixture, you need an extension bar with a 3/8" square drive (not included).

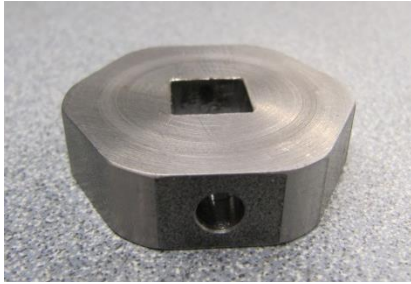

Figure 1: Rear Cushion Seat Fixture



Figure 2: Extension Bar (not included)

-Insert male square drive of the extension bar into the female square drive of the Rear Cushion Seat Fixture



Figure 3: Rear Cushion Seat Fixture w/ extension

Installation Process:

Step 1: Install Rear Cushion Seat

- Clean the threads of the Rear Cushion Seat and the Housing inside bore of accumulated oil and dirt using a suitable non-flammable solvent (Simple Green or equivalent). Completely dry the parts.
- Apply LOCTITE #680 or equivalent to the outer threads of the Rear Cushion Seat



Figure 4: Rear Cushion Seat

- Insert Rear Cushion Seat Fixture into Rear Cushion Seat



Figure 5: Rear Cushion Seat w/ fixture

- Set Rear Cushion Seat into the base of the housing, threading it into the Housing inside diameter.

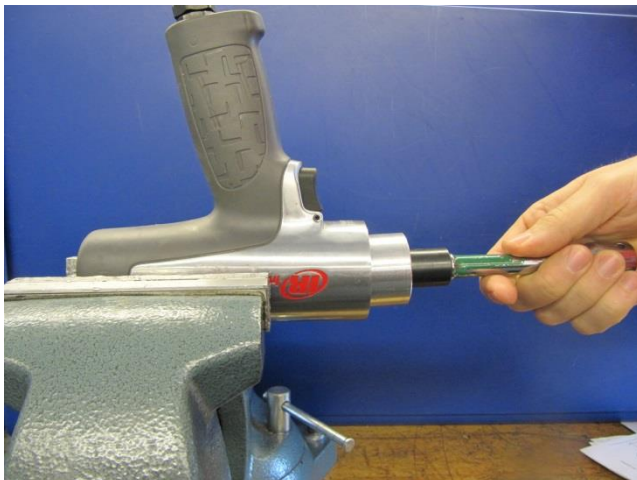

Figure 6: Setting Rear Cushion Seat

-Tighten the Rear Cushion Seat to a torque spec of 11 ft-lb (15 Nm)



Figure 7: Tightening Rear Cushion Seat

Alternative Method:

If you do not have the Rear Cushion Seat Fixture, you can use the hex on the Rear Cushion to install the Rear Cushion Seat.

-Insert Rear Cushion onto the barrel.



Figure 8: Rear Cushion on Barrel

-Insert the Rear Cushion Seat on the hex at the base of the Rear Cushion.



Figure 9: Rear Cushion Seat on Rear Cushion

-Insert Rear Cushion Seat into the housing. Once the treads are aligned properly, hand tighten the Rear Cushion. Next, torque the Rear Cushion to 11 ft.lb.



Figure 10: Tighten Rear Cushion Seat

Step 2: Install Rear Cushion

-Slide the O-Ring down the base of the Rear Cushion until it seats in its groove (see figure 8).

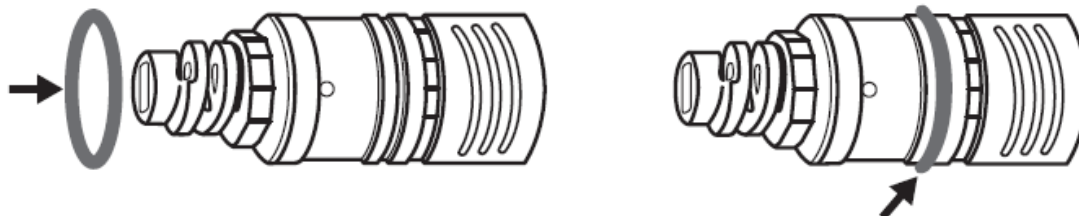

Figure 11: Install O-Ring

-Insert the Rear Cushion into the housing, being sure that it is fully seated in the hexagonal section of the Rear Cushion Seat.

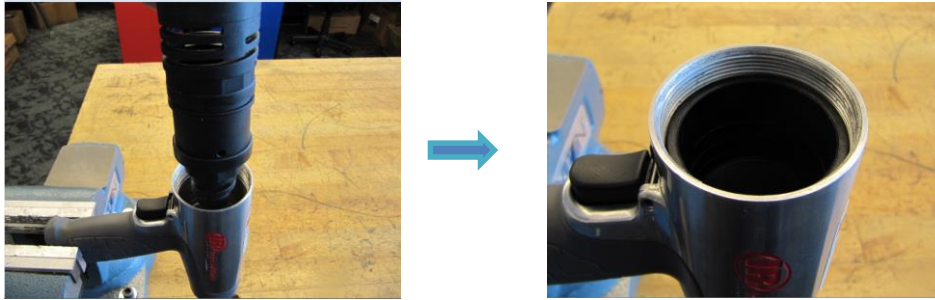

Figure 12: Insert Rear Cushion

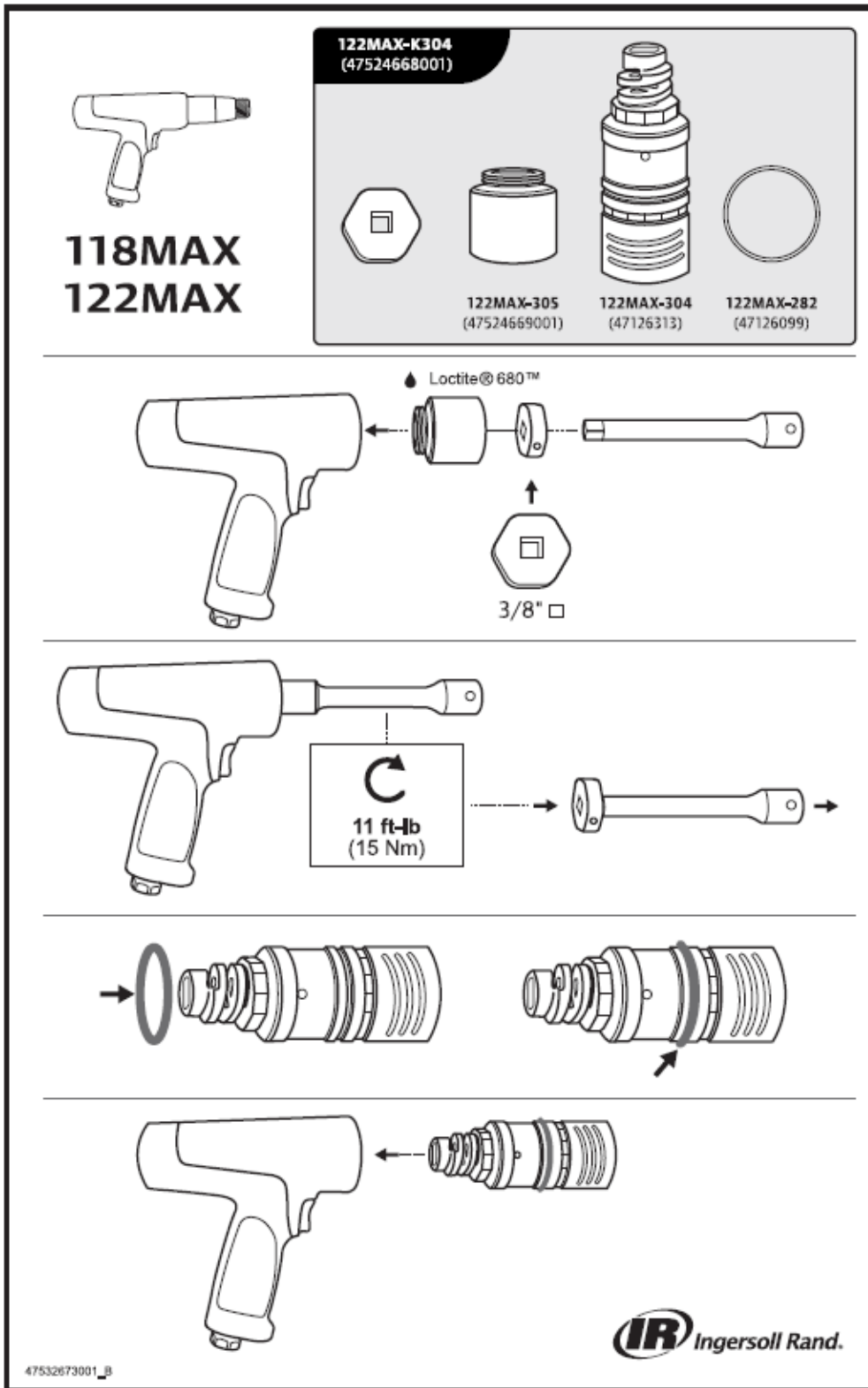

Figure 13: Service Instruction Sheet

Additional Comments:

Tools manufactured with serial numbers from BA15B0401-BA15C0241 come preassembled with the new cushion and cushion seat.

Tools manufactured after serial number BA15C0241 have a redesigned housing and the new cushion.

Warranty Strategy

This repair is warrantable on tools manufactured before serial number BA15B0401 that have experienced a Rear Cushion failure. The tool must still have warranty coverage in effect (12 months or less time in service).

Recommended 2nd Level Distribution:

Please distribute to all regional customer support and service personnel.

For Additional Information:

Ingersoll Rand Technical Support
United States: 800-483-4981
Email: irtechsupport@irco.com